

**ILLUSTRATED PARTS CATALOG
STC SR00811SE**



**ENGINE INLET BARRIER FILTER SYSTEM
Eurocopter AS350B Series**

This document provides information to assist with the identification of parts and assemblies for the 1350IN1-1/-7/-17 Engine Inlet Barrier Filter System installed on the Eurocopter AS350B, BA, B1, B2 & B3 (single hydraulics) Series helicopters in accordance with STC SR00811SE.

RECORD OF REVISIONS

REV	DATE	DESCRIPTION	BY	APPV'D
IR	1/13/2009	Initial Release	RJK	REB
A	02/09/2009	Added parts (17-24) omitted on initial release for Alternate Air Assy. also pages 20 & 21.	RJK	REB
B	05/31/2011	Completely revised.	BEV	BEV

The information contained in this document is for information purposes only, and is not to be used for maintenance. The parts and assemblies indicated in this document are the only parts and assemblies authorized by FDC/aerofilter for replacement on FDC/aerofilter products.

The data contained herein is not FAA approved, and is provided by FDC/aerofilter for information purposes only. While every effort has been made to ensure the accuracy and completeness of this information, FDC/aerofilter cannot be held liable for errors or omissions.

It is the responsibility of the user of this document to verify that it is the latest revision released by FDC/aerofilter Product Support. It is FDC/aerofilter's intention to provide our customers with the best possible support and assistance with our products. Please contact us using the information below to get the latest version of this and other documents. FDC/aerofilter also welcomes your reports of errors or omissions, and we value your suggestions to improve this and other documents.

FDC/aerofilter
3920 Sandstone Dr.
El Dorado Hills, CA 95762
Tel: 415-884-0555
Fax: 415-884-0505
Toll-Free (US & Canada): 800-350-6674

www.fdcaerofilter.com

Documentation Feedback

FDC/aerofilter welcomes your reports of errors or omissions, and we value your suggestions to improve this and other documents.

Return via FAX or e-mail to: FDC/aerofilter Product Support (415) 884-0505
support@fdcaerofilter.com

Page: _____ **Item #:** _____

Now Reads: _____

Should Read: _____

Comments: _____

Your Name: _____

Address: _____

Position: _____ **Telephone No:** _____

Company: _____

Filter System: P/N 1350IN1-1/-7/-17

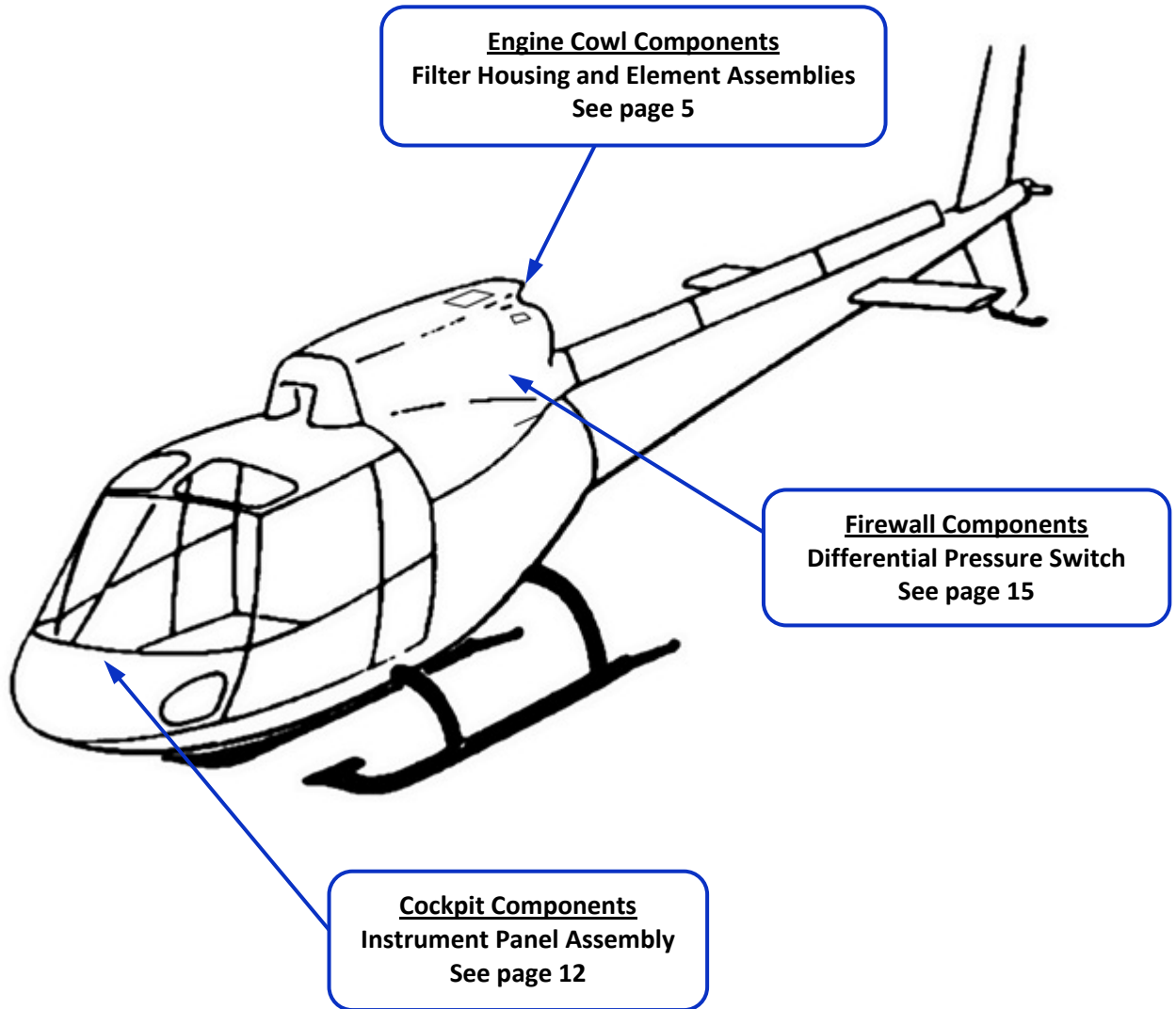

Filter System Installation in Engine Cowl

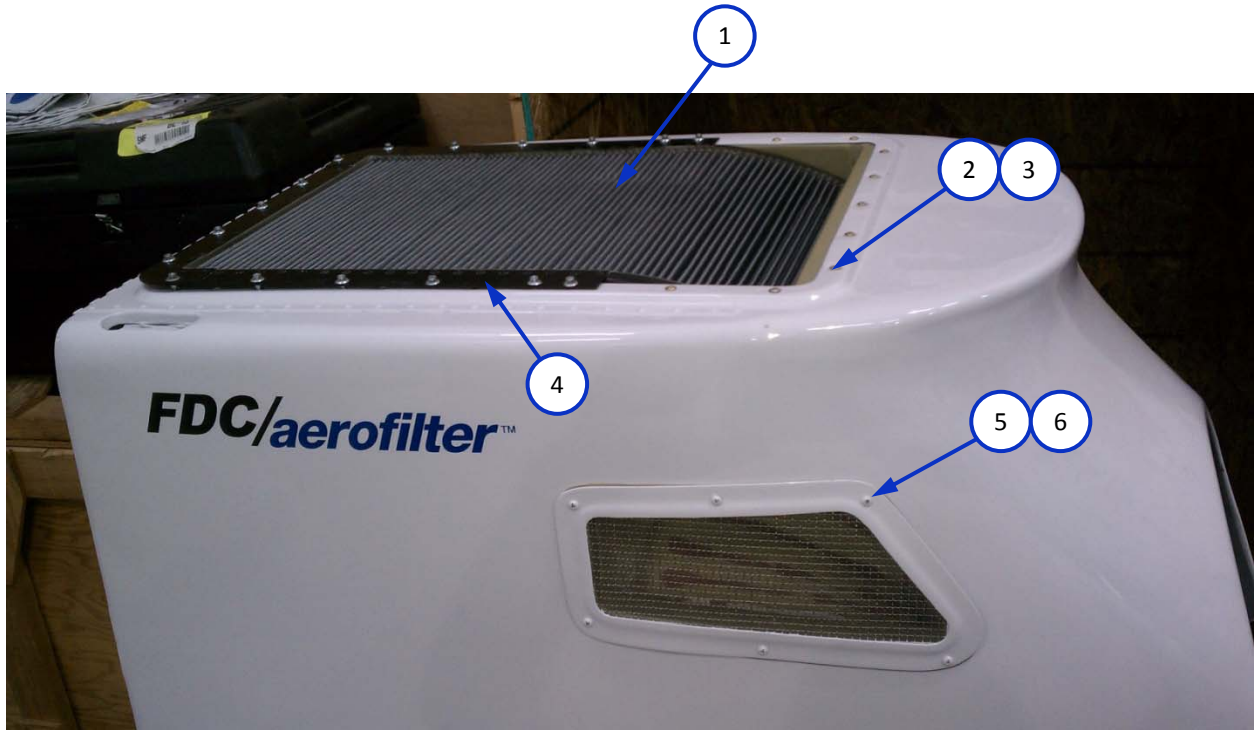

ITEM	PART NUMBER	ITEM NAME	APPEARANCE	QTY.
1	(1)	Filter System	---	1
2	NAS603-6P	Screw	---	9
3	NAS1149F0316P	Washer	---	9
4	NAS514P832-6	Screw (located under flange of element)	---	6
5	NAS602-6P	Screw	---	12
6	NAS1149FN816P	Washer	---	12

(1) See "Filter System Outside of Engine Cowl" for breakdown.

Filter System Outside of Engine Cowl

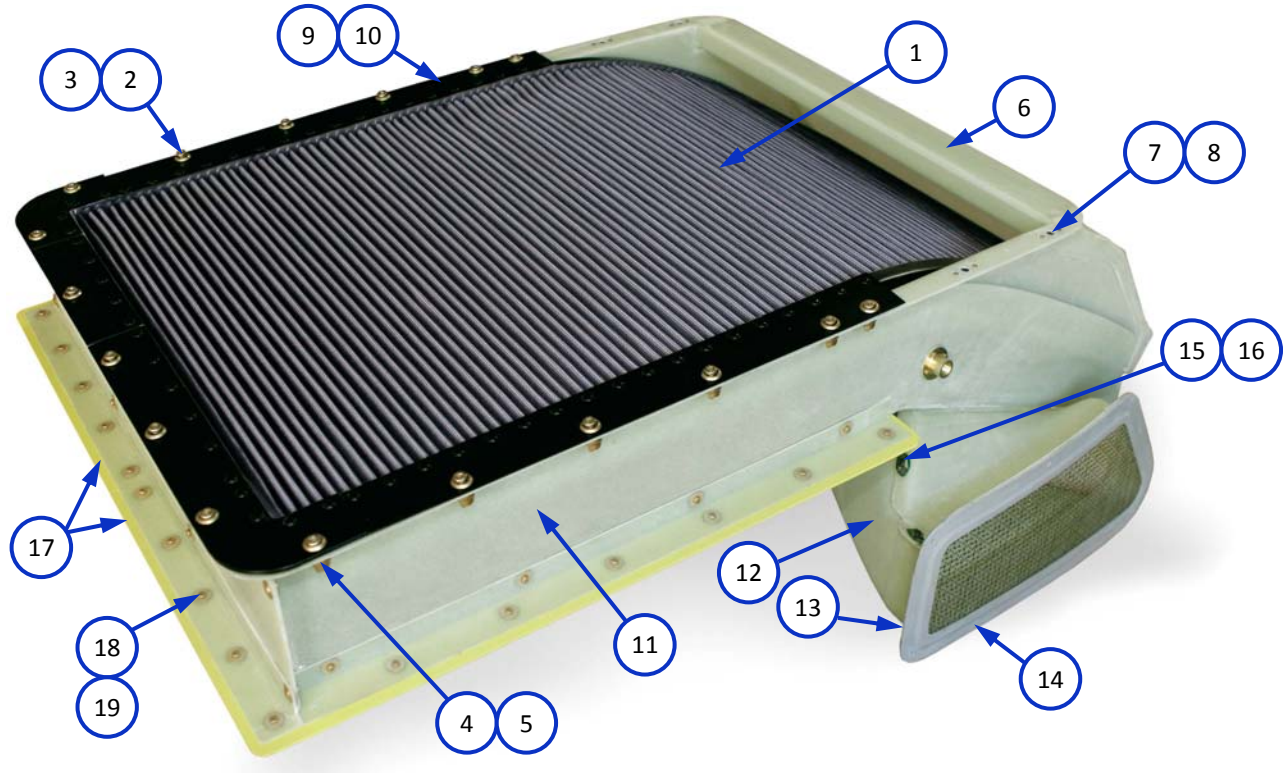





ITEM	PART NUMBER	ITEM NAME	APPEARANCE	QTY.
1	1350A2-1	Filter Element	See above	1
2	26S8-6	Stud	See above	17
3	2600-LW ⁽¹⁾	Retaining Ring	See above	17
4	26R16-1 ⁽²⁾	Receptacle, Encapsulated	See above	17
5	MS20426A3-4-5	Rivet	See above	34
6	1350A3-1 (-1/-7 system) 1350A3-3 (-17 system)	Upper Housing Assembly	See above	1
7	MS21059L3	Nutplate (located on underside of upper housing flange)	---	9
8	MS20426AD3-4	Rivet	---	18
9	MS21059L08	Nutplate (located on underside of upper housing flange)	---	6
10	MS20426AD3-4	Rivet	---	12
11	1350A4-3	Lower Housing Assembly	See above	1
12	1350A6-1	Alternate Air Lower Housing	See above	1
13	1350P1-50 (LH) 1350P1-60 (RH)	Closure, Alternate Air Inlet	See above	1 1
14	1350P1-70 (LH) 1350P1-80 (RH)	Screen Assembly	See above	1 1



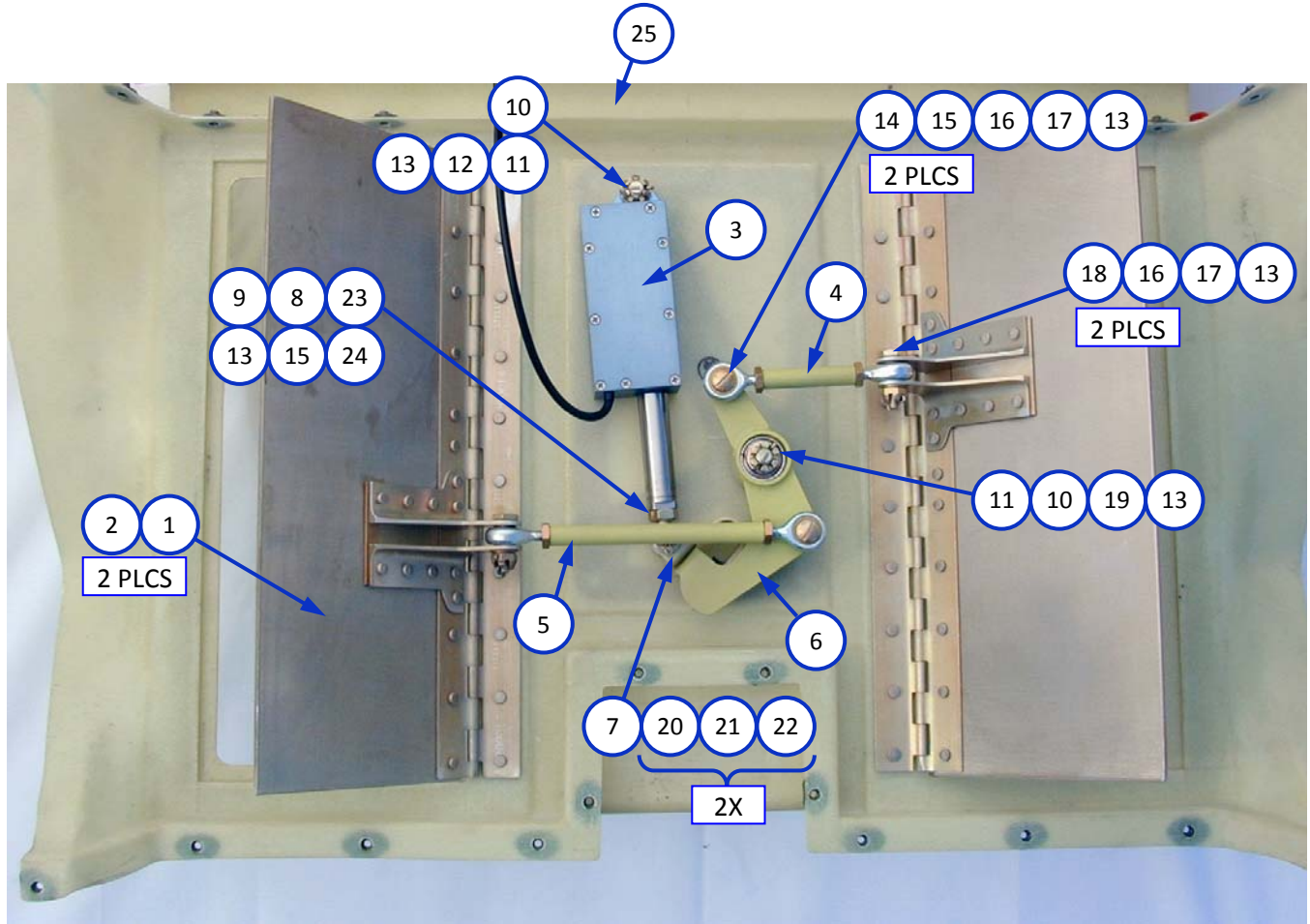

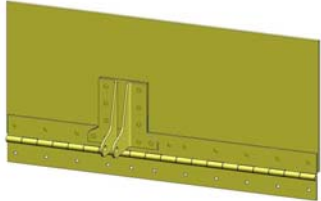
ITEM	PART NUMBER	ITEM NAME	APPEARANCE	QTY.
15	NAS601-6P	Screw	---	14
16	NAS1149FN816P	Washer	---	14
17	1350P3-203 ⁽³⁾	Reinforcement Plate	See above	2
18	MS20426AD4-5	Rivet	---	30
19	NAS1149DN516J	Washer	---	30

- (1) Alternate p/n: 1126004-6 Stud with 1127700 Retaining Ring or 26S107-6-1AA Stud.
- (2) Early filter systems were manufactured using p/n 212-12N non-encapsulated receptacle (Reference Service Bulletins SB.FDC.AS350.0013 & 0014).
- (3) Early filter systems were manufactured using p/n 1350P3-103/-104 reinforcement plates (Reference Service Bulletin SB.FDC.AS350.0012).

Alternate Air Assembly/Components
 (Located on underside of 1350A4-3 Lower Housing Assembly)



ITEM	PART NUMBER	ITEM NAME	APPEARANCE	QTY.
1	1350P2-3	Door Assembly		2
2	MS20426AD4-7	Rivet	---	22
3	A281-3 ⁽¹⁾	Linear Actuator (Supersedes P/N 1206-50-2A)		1
4	1350P2-9	Rod Assembly		1
5	1350P2-7	Rod Assembly		1

ITEM	PART NUMBER	ITEM NAME	APPEARANCE	QTY.
6	1350P2-1	Bellcrank Assembly		1
7	1350P2-121	Spring, Actuator		1
8	1350P2-115	Lug, Actuator		1
9	1350P2-133	Bushing, Actuator Lug		1
10	NAS1149F0432P ⁽²⁾	Washer	---	2
11	NAS1149F0416P ⁽³⁾	Washer	---	2
12	AN310-4	Nut, Castle	---	1
13	AN380-2-2	Pin, Cotter	---	7
14	AN23-12	Bolt, Clevis	---	2
15	NAS1149F0363P ⁽⁴⁾	Washer	---	3
16	NAS1149F0332P ⁽⁵⁾	Washer	---	4
17	AN310-3	Nut	---	4
18	AN3-6	Bolt	---	2
19	AN320-4	Nut, Castle	---	1
20	MS16997-31	Screw, #8-32 Socket Head Cap	---	2
21	NAS1149FN816P	Washer	---	2
22	MS21042L08	Nut, Self Locking, #8-32	---	2
23	MS35650-3252	Jam Nut	---	1
24	MS20392-2C23	Pin	---	1
25	MS35489-4	Grommet (located in 1350A6-1)	---	1

- (1) See Service Information Letter SIL.FDC.ALL.0012 for actuator exchange program.
- (2) Use for shimming as required. Located under actuator and above bellcrank as manufactured.
- (3) Use for shimming as required. Located above actuator and below bellcrank as manufactured.
- (4) At bellcrank connection. Located between rod end and bellcrank.
- (5) Located under nut.

Linear Actuator Electrical Terminations

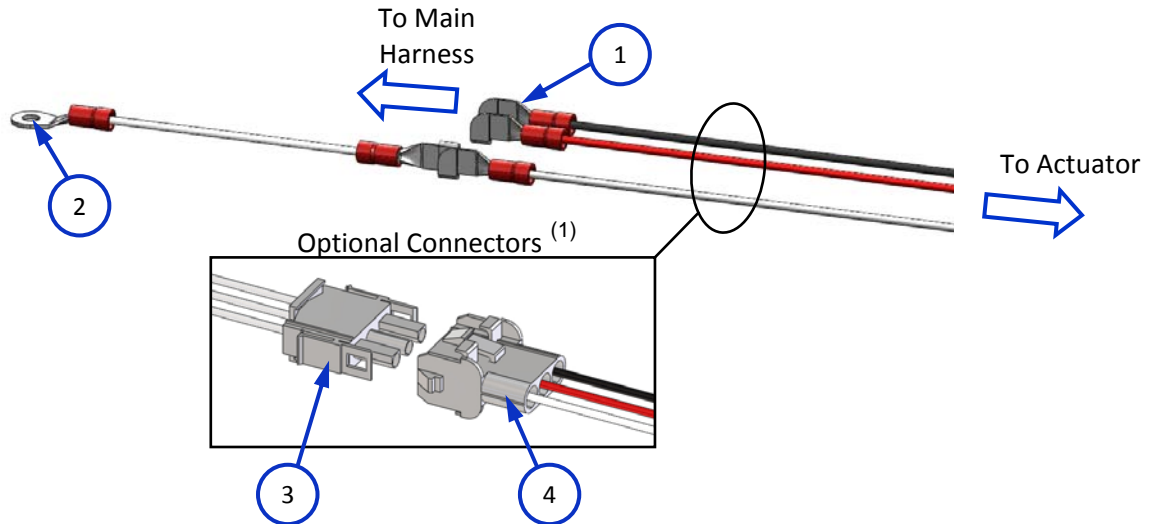

ITEM	PART NUMBER	ITEM NAME	APPEARANCE	QTY.
1	32446	Disconnect, Knife	See above	4
2	MS25036-149	Terminal Ring	See above	1
3	050-84-1030 ⁽¹⁾	Plug, 3 Socket Molex 42021 Series	See above	1
4	050-84-2030 ⁽¹⁾	Cap, 3 Pin Molex 42022 Series	See above	1

⁽¹⁾ Knife disconnects supplied on / with actuator harness and main harness may be replaced with optional Molex connectors listed above. Any 3 circuit plug and cap combination from the series listed is acceptable. Molex connectors not available from FDC/aerofilter.

Main Wire Harness

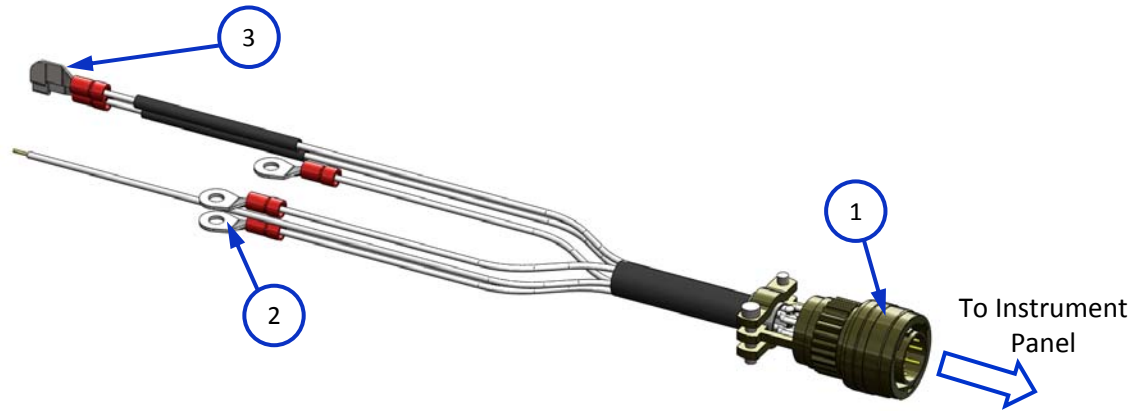

ITEM	PART NUMBER	ITEM NAME	APPEARANCE	QTY.
---	1350E1-1	Wire Harness	See above	1
1	MS3116F10-6P	Connector	See above	1
2	MS25036-149	Terminal, Ring	See above	3
3	32446	Disconnect, Knife	See above	2

Wire Harness for Differential Pressure Switch (DPS)

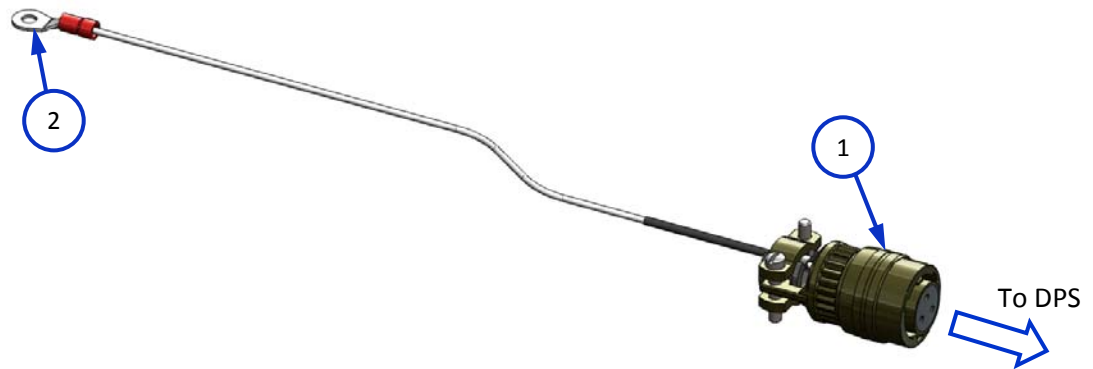

ITEM	PART NUMBER	ITEM NAME	APPEARANCE	QTY.
---	1350E1-3	Wire Harness	See above	1
1	MS3106F10SL-3S	Connector	See above	1
2	MS25036-149	Terminal, Ring	See above	1

Instrument Panel Assembly Installation



Instrument Panel Assy. Mounting Hardware (not shown above)

ITEM	PART NUMBER	ITEM NAME	APPEARANCE	QTY.
-	NAS602-8P	Screw	---	2
-	NAS1149DN832J	Washer	---	2
-	MS21042L08	Nut, Self Locking	---	2

Instrument Panel Assembly
(P/N 1350A11-1)

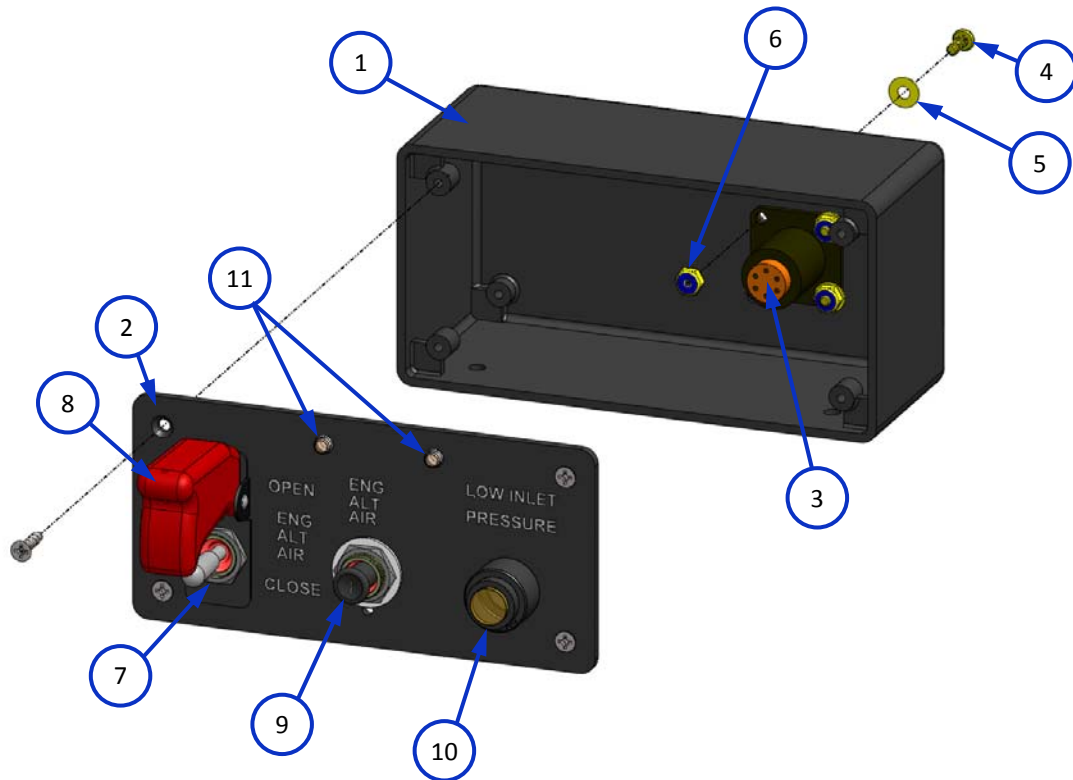

ITEM	PART NUMBER	ITEM NAME	APPEARANCE	QTY.
---	1350A11-1	Instrument Panel Assembly	See above	1
1	1350A11-103	Cover	See above	1
2	1350A11-101	Panel	See above	1
3	1350A11-3 ⁽¹⁾	Wire Harness (wires not shown)	---	1
4	MS35206-214	Screw	See above	4
5	AN960-4L	Washer	See above	4
6	MS21083N04	Nut, Locking	See above	4
7	MS35059-23	Switch Assembly	See above	1
8	MS25224-4	Switch Guard	See above	1
9	MS26574-1	Circuit Breaker Assembly	See above	1
10	MS25041-4-327	Light Assembly	See above	1
11	A350CN1WBKSH28	Post Light Assembly (not shown)		2

⁽¹⁾ See "Wire Harness, Instrument Panel Assembly" for breakdown.

Wire Harness, Instrument Panel Assembly

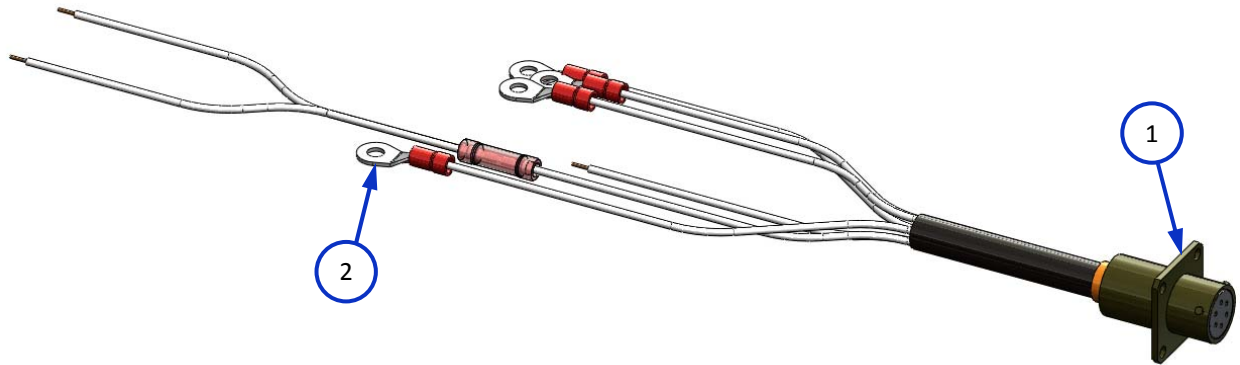

ITEM	PART NUMBER	ITEM NAME	APPEARANCE	QTY.
---	1350A11-3	Wire Harness	See above	1
1	MS3110E10-6S	Connector, Bulkhead	See above	1
2	MS25036-149	Terminal, Ring	See above	4

Differential Pressure Switch (DPS) Installation
(Preferred Location – Transmission Side of Firewall)

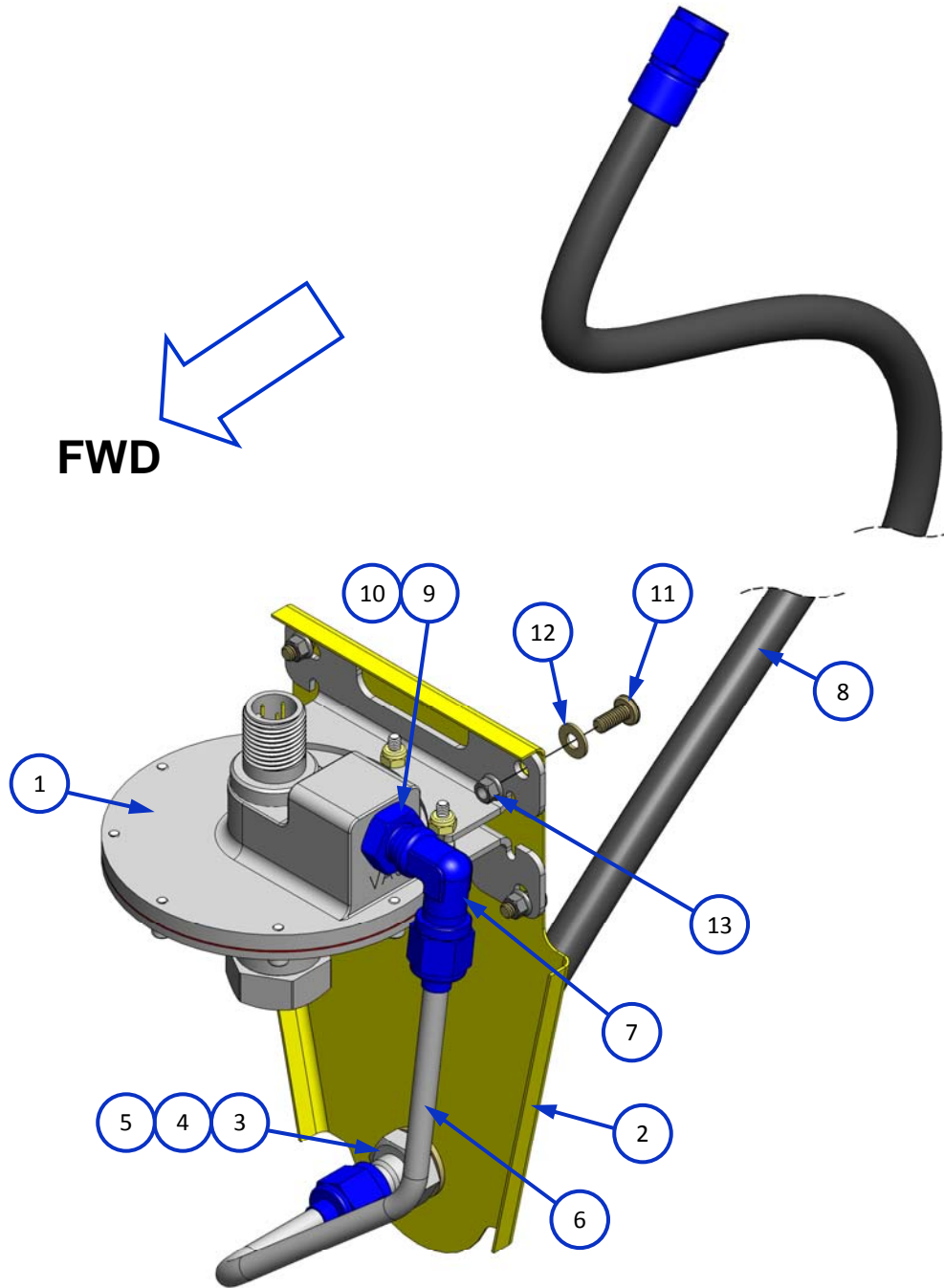

Differential Pressure Switch (DPS) Installation
(Alternate Location – Engine Side of Firewall) ⁽²⁾

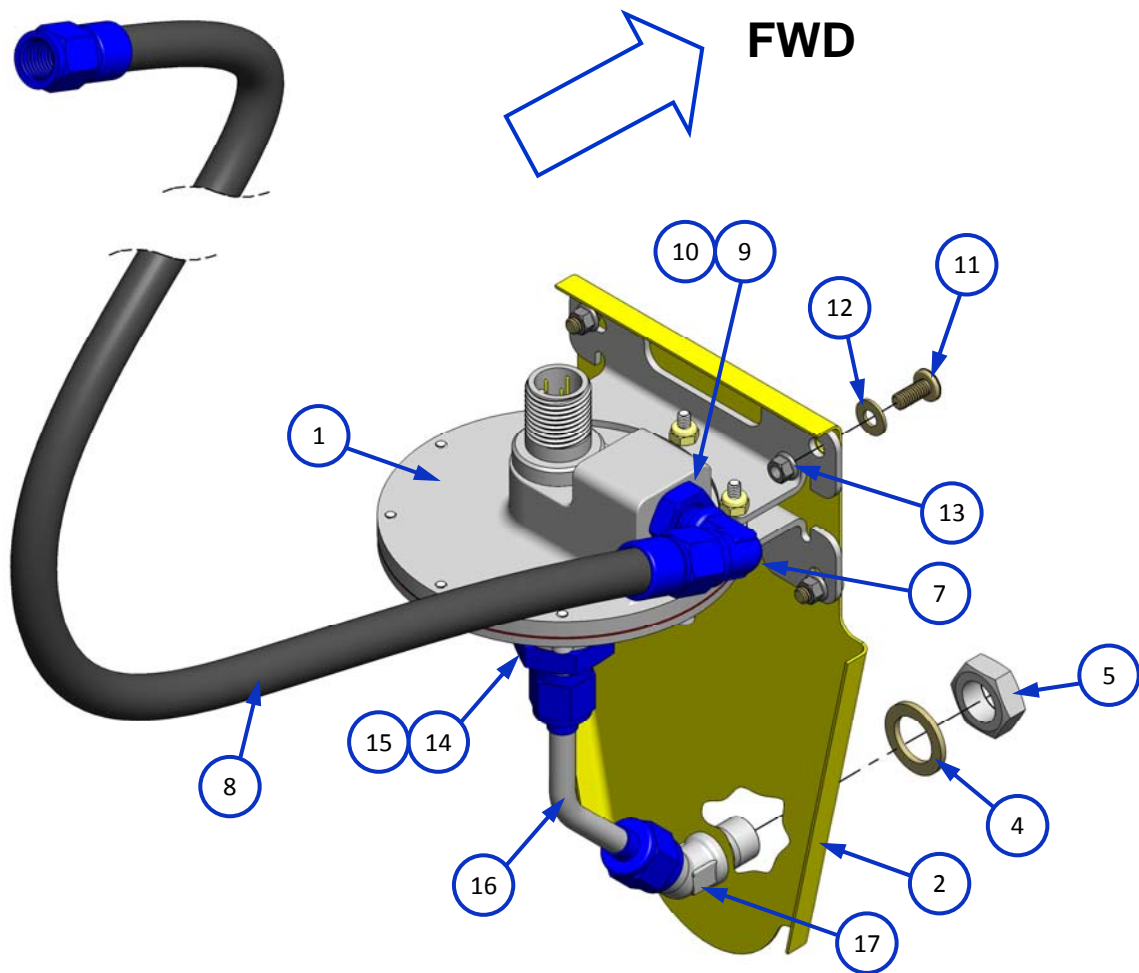

ITEM	PART NUMBER	ITEM NAME	APPEARANCE	QTY.
1	A486-1 ⁽¹⁾	Differential Pressure Switch	See above	1
2	1350P6-109	Plate	See above	1
3	AN837-4J	45° Fitting	---	1
4	NAS1149F0763P	Washer	---	1
5	AN924-4J	Nut	---	1
6	1350P6-5	Tube Assembly	See above	1
7	AN833-4D	Elbow	See above	1
8	1350P6-7 (-7/-17 system) 1350P6-3 (-1 system)	Hose Assembly	See above	1
9	MS28778-4	O-Ring	---	1
10	AN924-4D	Nut	See above	1
11	NAS602-6P	Screw	See above	4
12	NAS1149FN832P	Washer	See above	4
13	MS21042L08	Nut	See above	4
14	MS28778-4 ⁽²⁾	O-Ring	---	1
15	1350P6-103 ⁽²⁾	Fitting	---	1
16	1350P6-1 ⁽²⁾	Tube Assembly	See above	1
17	1350P6-107	Fitting	---	1

- (1) A486-1 supersedes p/n 98505-32210. If p/n A486-1 is used to replace p/n 98505-32210 for an installation on the engine side of the firewall, p/n 1350K1-1 Adapter Kit may be required (see note 2).
- (2) If p/n A486-1 DPS with a -7 size static port is installed on the engine side of the firewall, p/n 1350K1-1 Adapter Kit is required. MS28778-4 O-Ring, 1350P6-103 Fitting, and 1350P6-1 Tube Assembly are replaced by MS29512-07 O-Ring, 1350P8-101 Reducer, and 1350A17-1 Tube Assembly when 1350K1-1 Adapter Kit is installed.